

Goal • Practise interpreting circuit diagrams.

What to Do

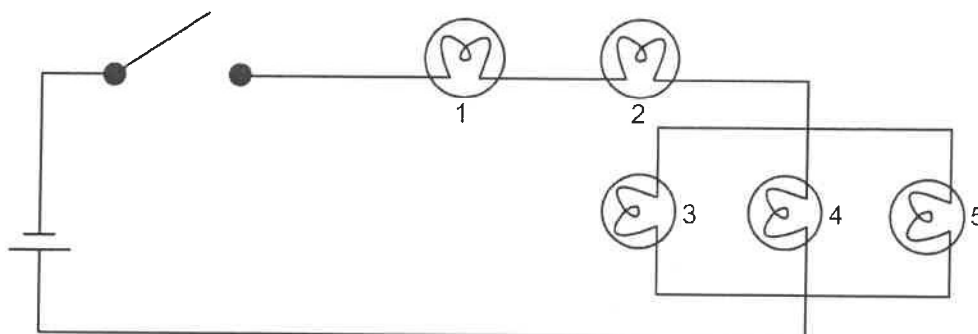

1. Describe what will happen in the circuit shown above if...

- (a) the switch is closed _____
- (b) the switch is closed and the first bulb is removed _____
- (c) the switch is closed and the fifth bulb is removed _____

2. Calculate the missing quantities for the circuit below.

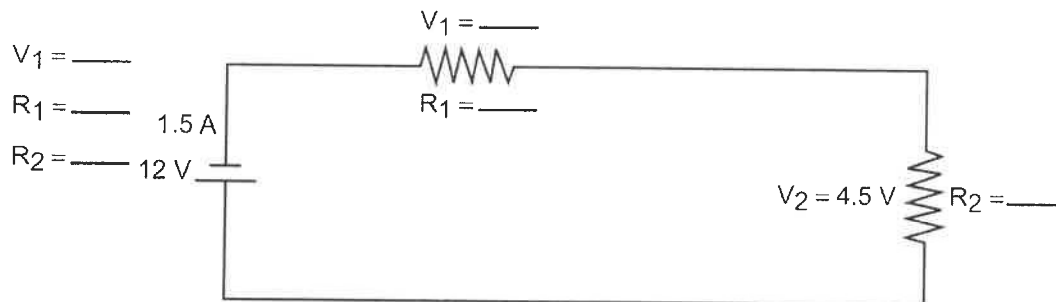

3. Calculate the missing quantities for the circuit below.

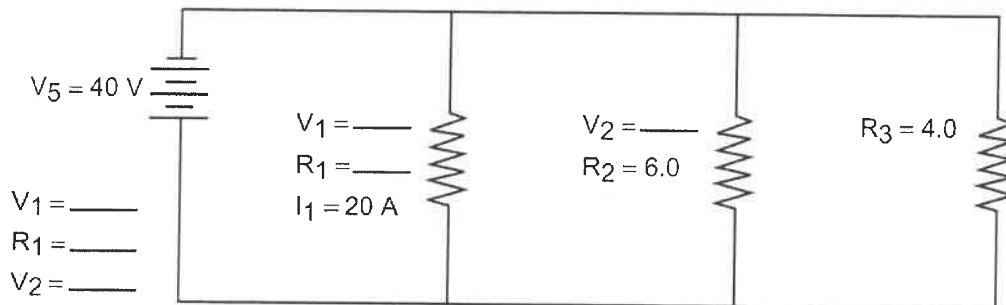

Goal • Practise calculating voltage and current in a circuit.

What to Do

Calculate the missing values in the circuits below. Be sure to show your calculations.

1.

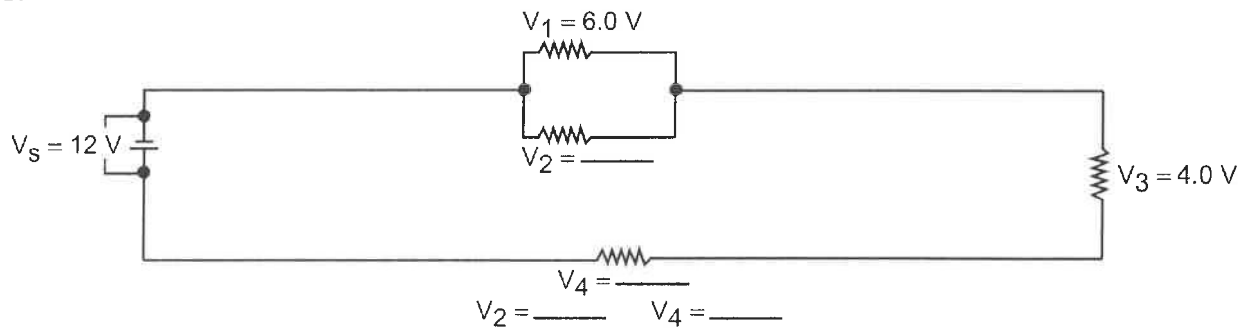

2.

